

**PRODUCT ID: 52172**  
LED Traffic Controller

**MODEL**  
TCILV-AA/120-277VAC



**DIMENSIONS**  
14" H x 7" W x 6" D (est. 3.009 lbs)

**CLASS**  
Class: TCIL Series

**CLASS**  
Control Method: Switch (not included) or external relay.

**CONSTRUCTION**  
Cabinet: Injection molded impact resistant polycarbonate housing and hood  
Faces: Single Faced Sign  
Finish: Duranodic Bronze  
Lens: Left or Top: Amber Impact resistant tinted Lexan®  
Lens: Right or Bottom: Amber Impact resistant tinted Lexan®

**ELECTRICAL**  
Flashing: Not Included  
Input Voltage: 120-277 VAC  
UL/cUL Listed: Listed for wet locations

**MESSAGE**  
Illumination: Super bright direct-view LEDs on replaceable circuit board.  
Sign Messages: See message table below

MESSAGE	LED/COLOR	HEIGHT	AMPS
Amber Indicator Dot	Amber Wide Angle LED	4.0"	0.036-0.015
Amber Indicator Dot	Amber Wide Angle LED	4.0"	0.036-0.015

NOTE: Above messages are independently controlled.

**Signal-Tech**  
4985 Pittsburgh Ave.  
Erie, PA 16509  
Phone: (877) 547-9900  
Fax: (814) 835-2300  
Email: sales@signal-tech.com  
Website: www.signal-tech.com



**Product View**

NOTE: Sign image may not exactly represent the finished product. For illustration purposes only.

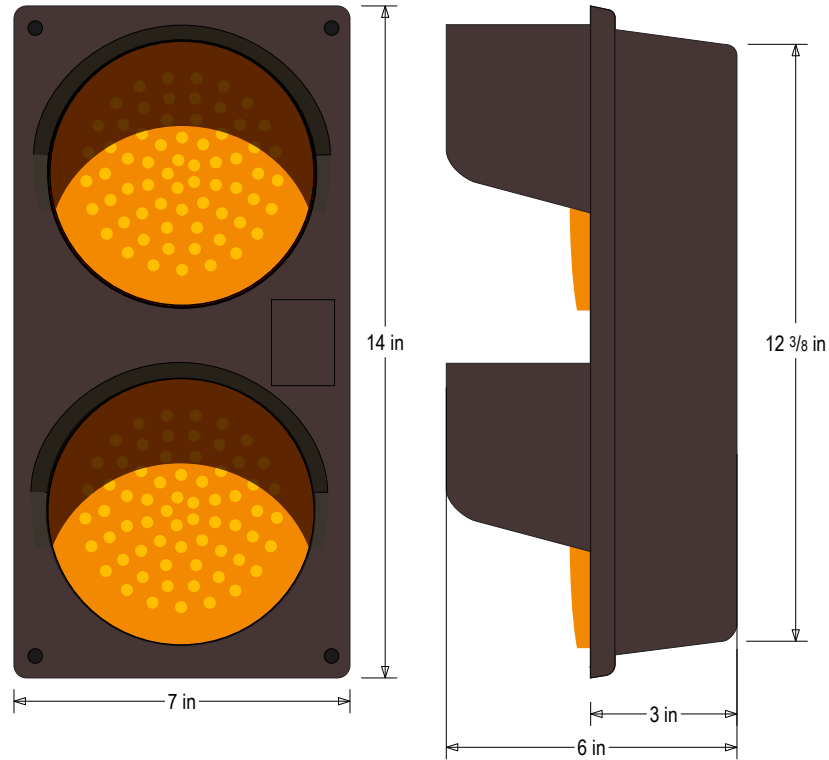

**Sample Display Options**

