

SA Series Monument Sign

120-277VAC or 12-24VDC Power and RS485 or RS232 Communications Wiring and Configuration

Voltage

This sign operates within an input range of 120-277VAC or 12-24VDC

Power & Communications

Bring input power and communications through the bottom or back of cabinet, using separate conduit for each. Weather proof all connections made through the cabinet.

IMPORTANT: Space Available signs **ONLY** require one power and one communication input. Multi-level signs are internally pre-wired at the factory.

Fig. 1: Board Locations

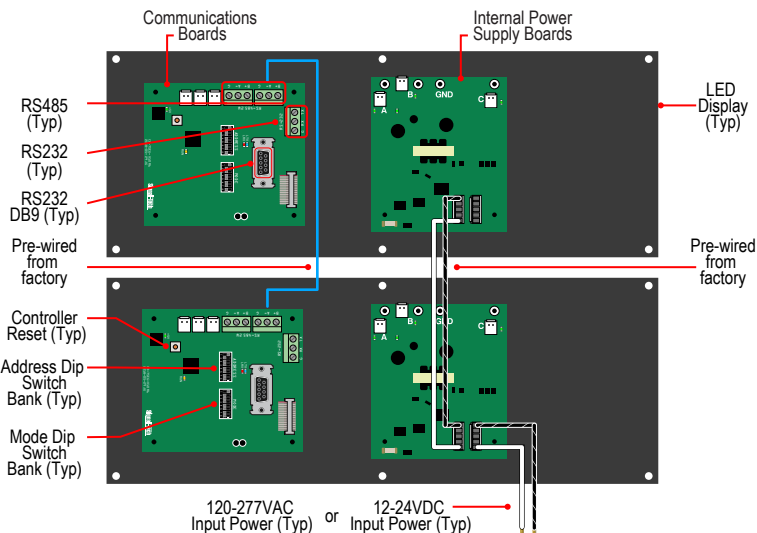
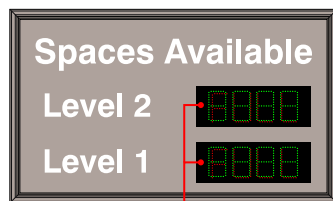

Power Wiring Connections

1. Turn off incoming power prior to starting installation.
2. Locate the internal power supply on the display. It is the circuit board with a large white pigtail connector.
3. Unplug pigtail connector from the supply. Connect to input power (*Note: some wires may not be used*)
 - a. 120-277VAC (Figure 2)
 - i. Hot: Black w/White Stripe
 - ii. Neutral: White
 - b. 12-24VDC (Figure 3)
 - i. Positive lead: Red
 - ii. Negative lead: Black
4. Plug the pigtail connector back into the power supply to finish; the connector is keyed and can only be installed in one orientation.

Fig. 2: Wiring a 120-277VAC Power Supply

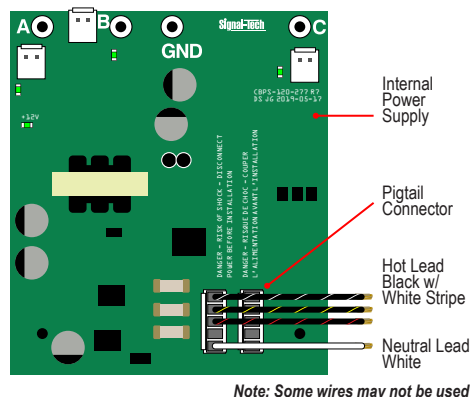
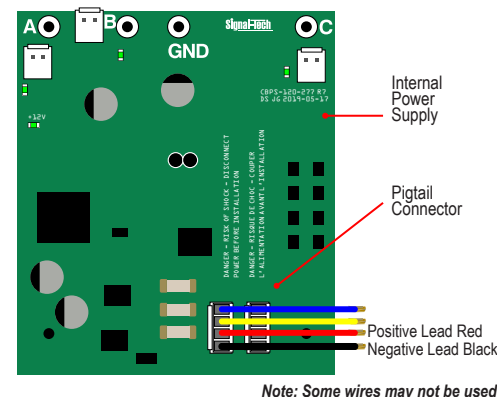

Fig. 3: Wiring a 12-24VDC Power Supply



Communications Wiring Connections

1. Connect the display to the network using RS485 (Figure 4), or RS232 (Figure 5).

Note for RS485 installations:
There are two ports to simplify daisy-chain wiring when two or more signs are used in series, either of which can be used.
2. Connect Ground wire as shown to ensure data integrity.
3. Communication settings: Follow guidelines in LED Count Display Protocol.

Fig. 4: RS-485 2-Wire Communications Wiring

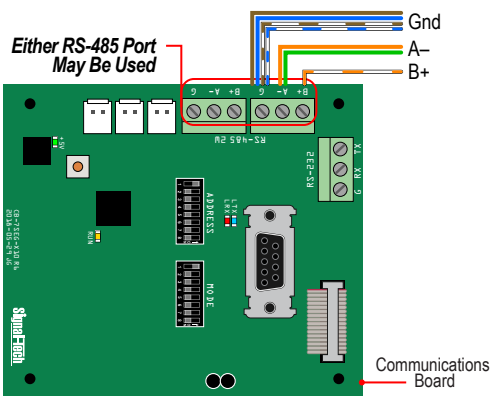
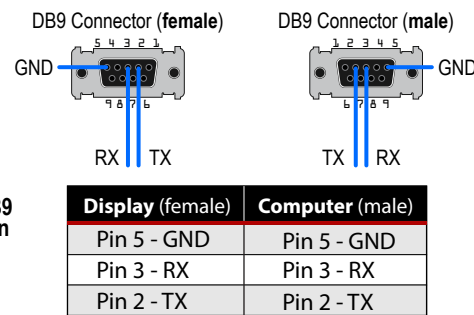
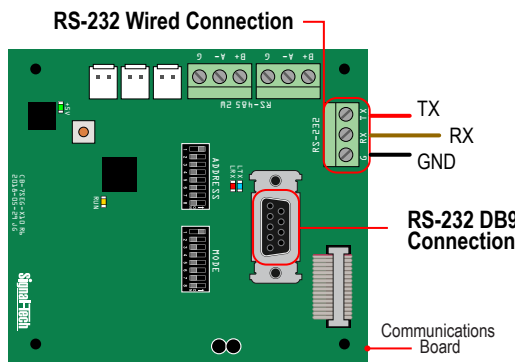

Fig. 5: RS-232 Alternative Communications Wiring



Setting the LED Display Sign ADDRESS

For Space Available Signs being integrated with a RedStorm™ System

Each LED Display needs an address to ensure it receives and displays the intended data. Refer to the Transition Point List that ships with your RedStorm System for the system address for the sign.

Typically, the factory default address is 01. To change the display address, use the Address DIP Switch Bank on the back of the display board. Refer to Figure 7 for DIP Switch settings for addresses from 01-10.

For Space Available Signs being integrated with a third-party system

Please refer to the third-party documentation for setup and configuration instructions.

DIP Switch Bank Settings

There are two DIP Switch Banks on the sign, one is for setting the ADDRESS and the other is for setting the Operating MODE. The "ON" position is UP as shown in Figure 6 and 8.

Fig. 6: DIP Switch ON Position

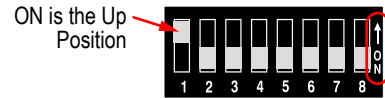

Note: The Address DIP Switch Bank uses a binary system to assign values. We recommend using a DIP Switch calculator for addresses greater than 10.

Fig. 7: Address DIP Switch Settings



Setting the LED Display Sign MODE

Mode DIP Switch Bank

The factory default settings for the Mode DIP Switch are noted with an asterisk (*). Changes can be made as needed in the field.

Fig. 8: Factory Default Settings



MODE

Switch	Position	Description
4	ON*	FULL message displays in Green LEDs
	OFF	FULL message displays in Red LEDs
5	ON	Enable Test Mode. Requires controller reset.
	OFF*	Normal operating mode

* Factory default setting

† Not available on all models

Warning Statements

Note: Make appropriate wiring connections per local code.

Note: Any holes drilled into sign cabinet **MUST** be sealed. Failure to do so may cause a short and void warranty.

Note: This unit contains a built-in CLASS 2 LED driver.

Note: This sign is intended to be installed in accordance with the requirements of Article 600 of the National Electric Code and/or other applicable local codes. This includes proper grounding and bonding of the sign.



WARNING: Risk of Fire or Electric Shock. Do Not interconnect output terminations.

AVERTISSEMENT: Risque d'incendie ou de choc électrique. Ne pas interconnecter les terminaisons de sortie.