

PRODUCT ID: 32336

Alarm Unit

MODEL

PA-WF-LV

DIMENSIONS

1.41" H x 1.41" W x 1.7" D (est. 0 lbs)

ELECTRICAL

Input Voltage:

Product View

NOTE: Sign image may not exactly represent the finished product. For illustration purposes only.

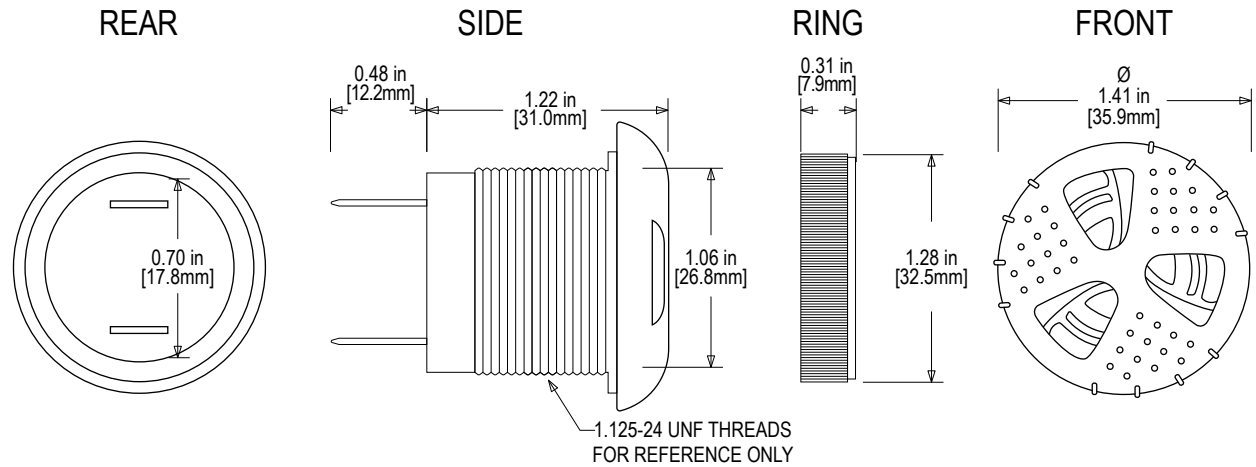

"Q" TERMINALS

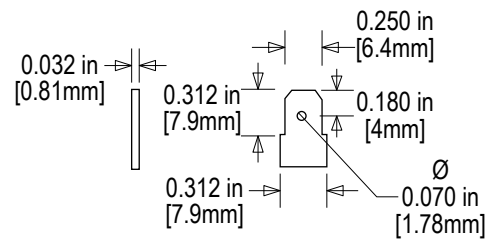

PANEL MOUNTING

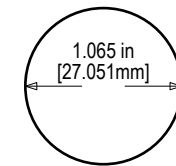

FITS PANELS UP TO 0.50in [12.7mm] THICK

TOLERANCES ARE ±0.03in [±0.76mm] UNLESS OTHERWISE SPECIFIED

Signal-Tech
4985 Pittsburgh Ave.
Erie, PA 16509
Phone: (877) 547-9900
Fax: (814) 835-2300
Email: sales@signal-tech.com
Website: www.signal-tech.com

