

Smart SA Series Insert Sign

120-277VAC or 12-24VDC Power and Ethernet Communications Wiring and Configuration

Voltage

This sign operates within an input range of 120-277VAC or 12-24VDC

Power & Communications

Bring input power and communications through the bottom or back of cabinet, using separate conduit for each. Weather proof all connections made through the cabinet.

IMPORTANT:

When controlling a Smart Space Available Sign with the RedStorm™ Sign Control and Reporting Software it is **CRITICAL** to complete the Smart Sign Install Log during installation. The information entered in the log will be used to setup and configure the sign functionality in the software.

How to complete the Smart Sign Install Log:

1. Write in the Facility Location
2. Write in the specific sign location at the facility
3. Remove the Product ID# and MAC address sticker from inside the sign and place it next to the sign location on the log chart
4. Repeat for each Smart Sign being installed.

Power Wiring Connections

1. Turn off incoming power prior to starting installation.
2. Locate the internal power supply on the display. It is the circuit board with a large white pigtail connector.
3. Unplug pigtail connector from the supply.

Connect to input power

- a. 120-277VAC (Figure 1)
 - i. Hot: Black w/White Stripe
 - ii. Neutral: White
 - b. 12-24VDC (Figure 2)
 - i. Positive lead: Red
 - ii. Negative lead: Black
4. Plug the pigtail connector back into the power supply to finish; the connector is keyed and can only be installed in one orientation.

Fig. 1: Wiring a 120-277VAC Power Supply

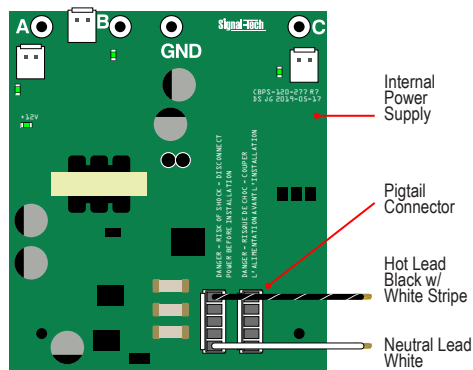
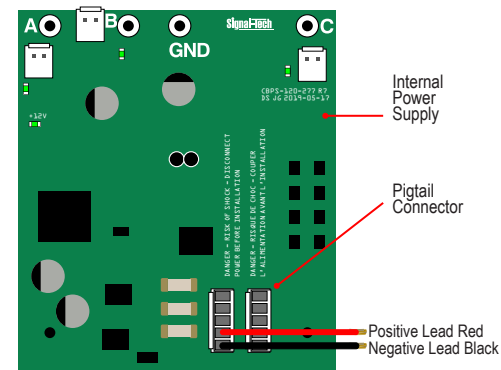

Fig. 2: Wiring a 12-24VDC Power Supply



Communications Wiring Connections

1. Make the wired Ethernet connection at the sign (Figure 3), **then** power the sign on.
 - a. Powering on the sign will trigger a DHCP request for an IP address from the network.
 - b. Sign will appear on the network in this format; **STSC##** (Use the Smart Sign Install Log to cross-reference each sign with its MAC address.)
2. Assign the sign a static IP lease/reservation on your network.
 - a. For instructions on how to assign a static IP address, refer to our FAQs/Knowledge Base at signal-tech.com/information-center/faq.
3. If using RedStorm Sign Control & Reporting Software.
 - a. Add the sign into the software using its assigned IP address. **Note:** Sign will not illuminate until it's assigned a schedule or manual override in the software.
 - b. Refer to the RedStorm Sign Control & Reporting Software Manual for setup and configuration instructions.
4. If using a third-party control software/system, please refer to their support documentation for setup and configuration.

Fig. 3: Board Locations

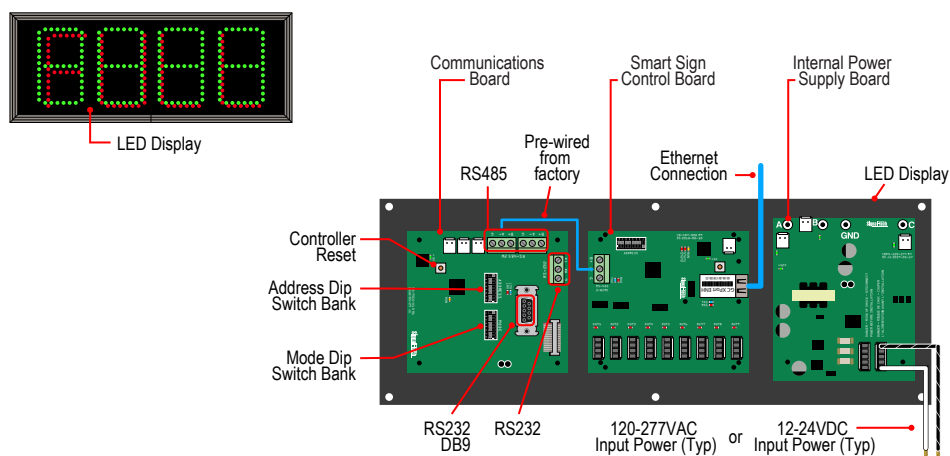

Warning Statements

Note: Make appropriate wiring connections per local code.

Note: Any holes drilled into sign cabinet **MUST** be sealed. Failure to do so may cause a short and void warranty.

Note: This unit contains a built-in CLASS 2 LED driver.

Note: This sign is intended to be installed in accordance with the requirements of Article 600 of the National Electric Code and/or other applicable local codes. This includes proper grounding and bonding of the sign.



WARNING: Risk of Fire or Electric Shock. Do Not interconnect output terminations.

AVERTISSEMENT: Risque d'incendie ou de choc électrique. Ne pas interconnecter les terminaisons de sortie.