

Incandescent Traffic Signal TCIH-BA

PRODUCT NUMBER

4519

CABINET DIMENSIONS

14" H x 7" W x 9" D

ILLUMINATION SOURCE

Heavy duty, vibration resistant traffic grade lamps
Long life; Up to 10,000+hours

ELECTRICAL

120 VAC Standard
UL/CUL Approved for wet locations
Heavy-duty porcelain sockets with copper screw shell
(2) R-20, 53 Watt lamps included
(Interchangeable with LED light engines)

CONSTRUCTION

Cabinet: injection molded impact resistant polycarbonate housing and hood
Raceway: .050 Aluminum
Lens Material: Impact resistant tinted Lexan®
Lens Colors: Red, Green, Amber, Blue, and Clear

FINISH

Standard Cabinet Color: Duranodic Bronze
Custom colors available upon request

Product View

NOTE: Sign image may not exactly represent the finished product. For illustration purposes only.

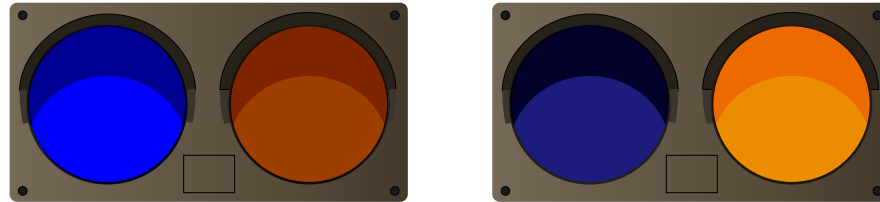
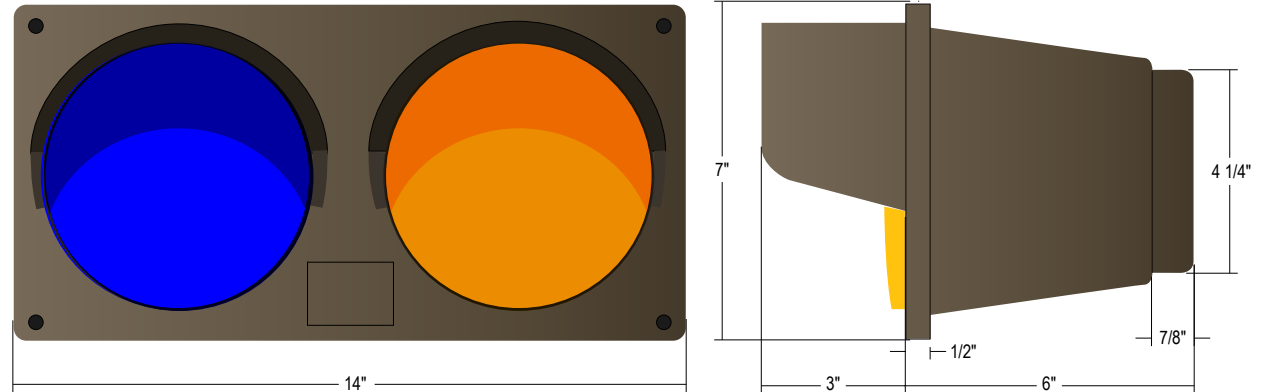

R20 53 Watt Heavy-Duty Traffic
Medium Base Screw-In Lamp



10,000-Hour Life Expectancy

MESSAGE	COLOR	HEIGHT	WATTS
Indicator Dot	Blue Lens	5.5"	53
Indicator Dot	Amber Lens	5.5"	53

Signal-Tech
4985 Pittsburgh Ave.
Erie, PA 16509
Phone: (877) 547-9900
Fax: (814) 835-2300
Email: sales@signal-tech.com
Website: www.signal-tech.com



Proudly Made in the USA